

Isolator/signal converter SP-11

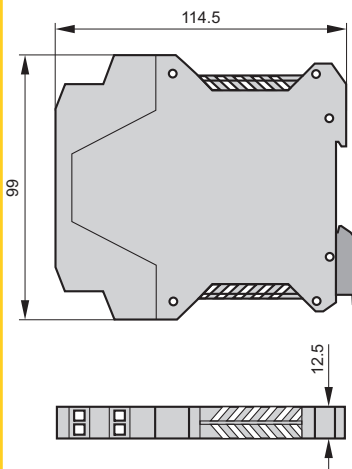

- ✓ Single circuit or dual circuit version in 12,5 mm wide casing
- ✓ Opto-electronic galvanic separation (IN-OUT)
- ✓ Ability to select input signal
- ✓ 9...36 V power supply in the output signal loop
- ✓ Casing can be fitted on a standard rail (TS35)



Applications and functions

The SP-11 signal isolator provides galvanic isolation of an input current or voltage signal and converts it, through a separation system into an output signal 4...20 mA with a two-wire power supply in the output signal loop.

The device is typically used to provide galvanic isolation between the measurement circuits installed on an object, and the main section.

Configuration, calibration

The user can use switches to configure input and output settings for the following signals

Technical parameters

- **Input parameters**
 - Input signal (selected by switch)**
 - 0...20 mA, 4...20 mA, 0...5mA, 1...5mA,
 - 0...10 V, 2...10V
 - Input resistance**
 - ≥ 50 kΩ (voltage input) / 20 Ω (current input)
- **Output parameters**
 - Output signal:** 4...20 mA
 - Load resistance:** 0...500 Ω
- **Galvanic separation:** opto-electronic
 - Strength test parameters**
 - 1,5 kV AC, 50 Hz, 1 min
- **Dynamic characteristics**
 - Transmission band:** 5 Hz (3 dB)
- **Power supply**
 - Supply voltage:** 9...36 V
- **Conditions of normal use**
 - Ambient temperature:** 5...60°C
 - Relative humidity:** 30...80%
- **Casing**
 - Type:** UEGM 22.5 (PHOENIX)
 - Ingress protection rating:** IP20
- **Weight:** 0,1 kg
- **Conversion errors**
 - Accuracy:** ≤ ±0,16%
 - Typically, the converter is set for the range 4...20 mA / 4...20 mA. Setting of a different range will lower the class of the converter to 0,25% (tuning is possible using trimmers accessible from the front plate).

Electrical diagram

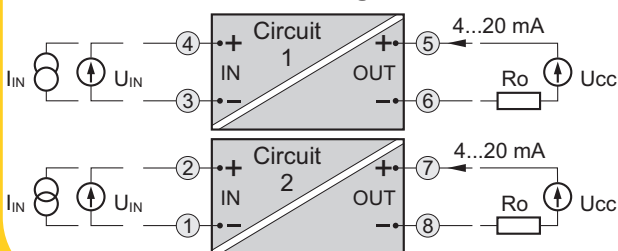

Ordering procedure

