

Threaded chemical seals with large diaphragm S-CompCh

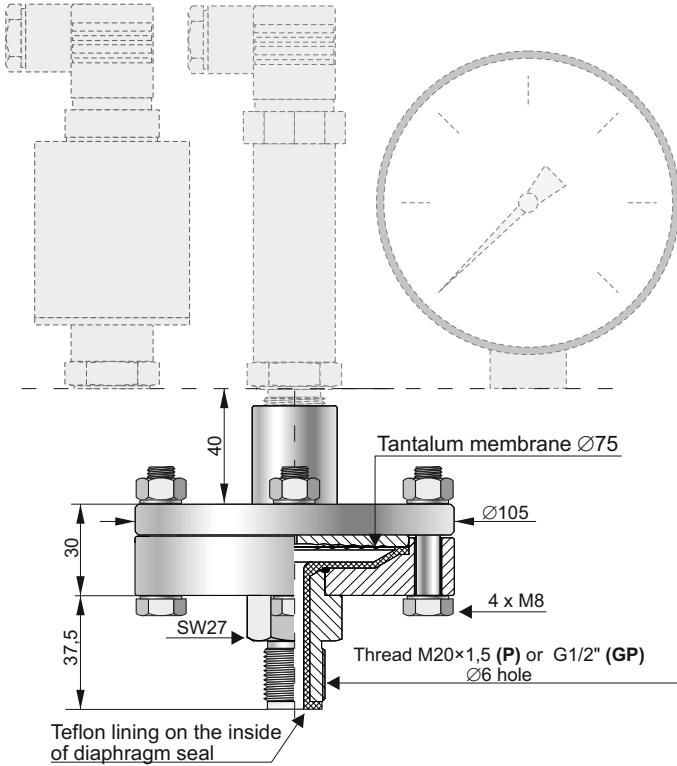

- ✓ Measurement the pressure of hydrochloric, sulphuric and nitric acids in any concentration
- ✓ Measurement the pressure of chlorine

Application

S-CompCh seals are applicable for measuring the pressure of corrosive media. The wetted parts of the diaphragm seal are made of Teflon and tantalum. Several corrosive chemicals, except for hydrofluoric acid, gaseous fluorine and soda lye, can be measured.

Recommended minimum measuring range (bar), depending on the type of the set: pressure measuring device - diaphragm seal

Diaphragm seal type	Transmitter	Gauge Ø100
direct	0.4	1
remote	1	6

Zero error from ambient temperature change

direct diaphragm seal: 5 mbar / 10°C

An additional zero error, resulting from temperature fluctuations in a medium, depends on the temperature gradient in the oil-based diaphragm sealing system. The error value is, in any case, significantly smaller than the error value shown above.

Maximum measuring range	0...16 bar
Over pressure limit	25 bar
Medium temperature range	-30...100°C

Ordering procedure

Model	Code	Description
S-CompCh		Direct diaphragm seal, tantalum membrane, max pressure 16 bar
type of process connection	/P.....	Thread M20x1.5
	/GP.....	Thread G1/2"

Example: APC-2000ALW - pressure transmitter, nominal measuring range 0÷7 bar, threaded chemical seal with large diaphragm, GP process connection G1/2".

APC-2000ALW / 0 ÷ 7 bar / S-CompCh / GP